

de Raumbediengerät ecoUnit110...146
 fr Boîtier d'ambiance ecoUnit110...146
 en Room operating unit ecoUnit110...146
 it Unità di servizio ambiente ecoUnit110...146
 es Unidad ambiente ecoUnit110...146
 sv Rumsenhet för ecoUnit110...146
 nl Ruimtebedienerenheid ecoUnit110...146

de Montagevorschrift
 fr Instructions de montage
 en Fitting instructions
 it Istruzioni di montaggio
 es Norma de montaje
 sv Monteringsanvisningar
 nl Montagevoorschrift

EY-RU110F2..
 EY-RU146F2..

de Montagevorschrift für die Elektrofachkraft
 fr Instructions de montage pour l'électricien
 en Fitting instructions for the electrician
 it Istruzioni di montaggio per l'installatore elettrico
 es Norma de montaje para el electricista
 sv Monteringsanvisningar för behörig elektriker
 nl Montagevoorschrift voor de elektromonteur

de Verschmutzungsgrad II, Bemessungsstossspannung 800 V
 fr Degré de pollution II, Tension de choc assignée 800 V
 en Pollution degree II, rated impulse voltage 800 V
 it Grado di insudiciamento II, tensione impulsiva di dimensionamento 800 V
 es Grado de suciedad II, Impulso de tensión medido 800 V
 sv Grad av nedsmutsningsgrad II, Märkstötspänning 800 V
 nl Vervuilinggraad II, nominale stootspanning 800 V

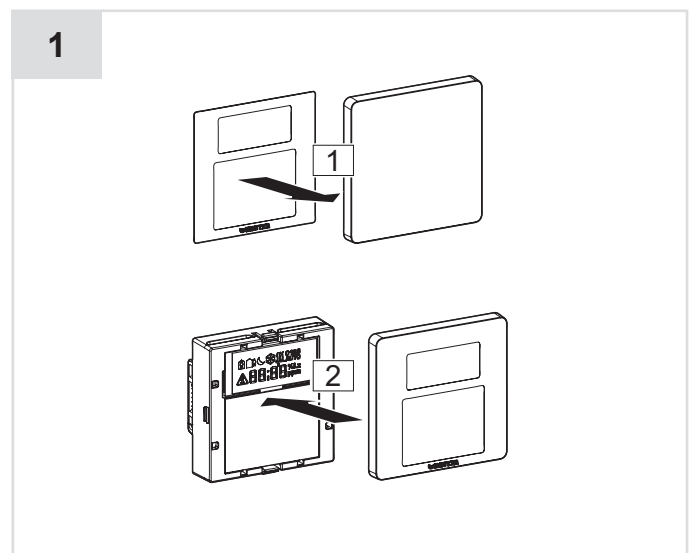
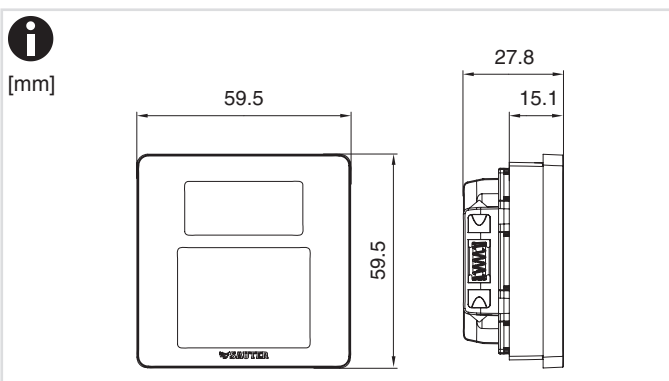
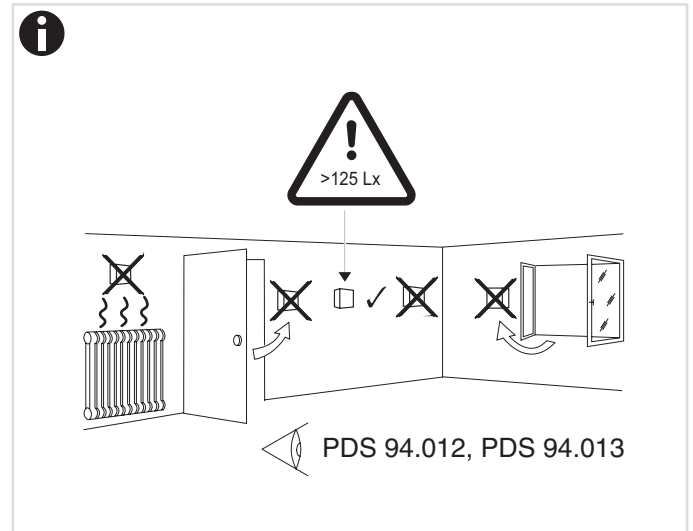
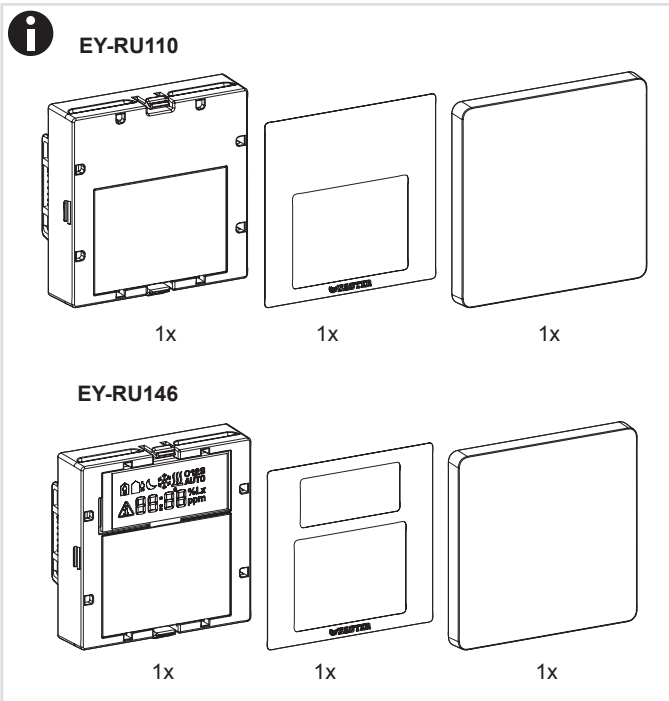
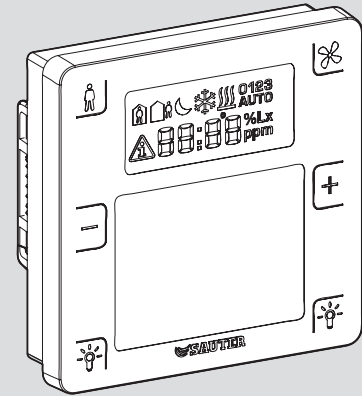

2

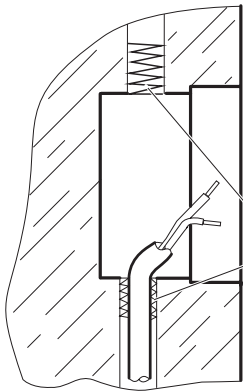

de abdichten
fr rendre étanche
en seal
it otturare
es junta
sv avtätning
nl afdichten

3

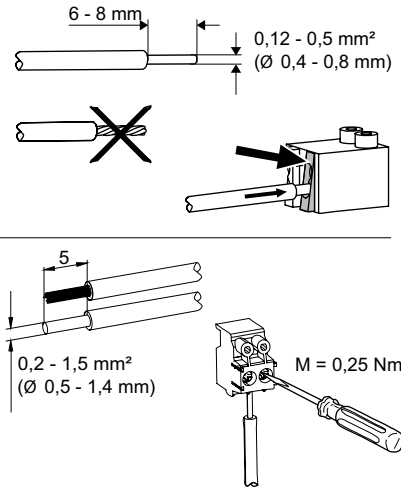

4

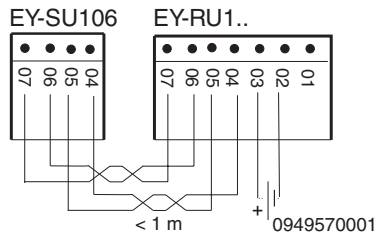
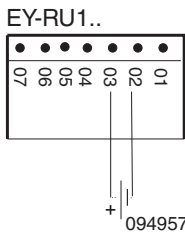
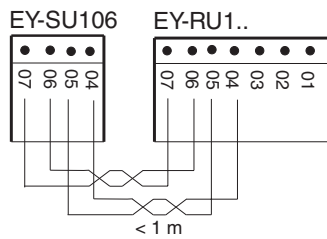
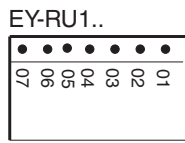

de Nur Batterie 0949570001 verwenden
fr Utiliser exclusivement une batterie 0949570001
en Only use battery 0949570001
it Utilizzare solo la batteria 0949570001
es Utilizar solo batería 0949570001
sv Använd endast batteri 0949570001
nl Uitsluitend batterij 0949570001 gebruiken

5

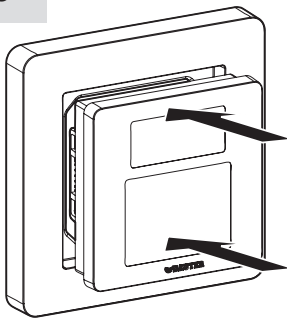

6

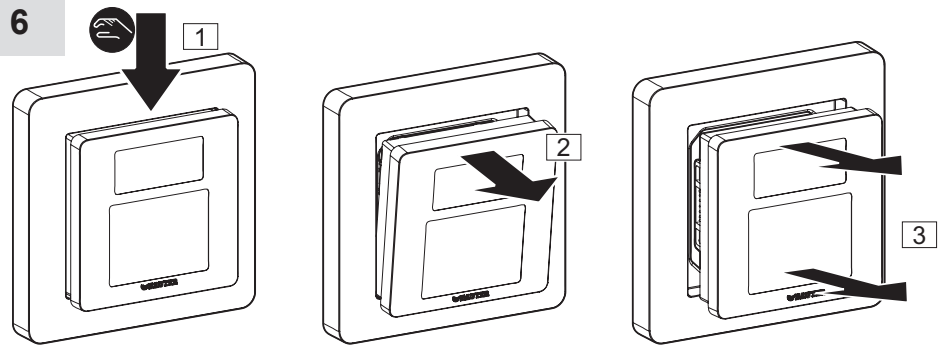

de www.sauter-controls.com ⇒ Produkte ⇒ Material- und Umweltdeklaration
Gerät enthält Batterie.
fr www.sauter-controls.com ⇒ Produits ⇒ Déclaration matériaux et environnement
L'appareil comprend une batterie.
en www.sauter-controls.com ⇒ Products ⇒ Materialdeclaration
Device contains battery.
it www.sauter-controls.com ⇒ Products ⇒ Materialdeclaration
L'apparecchio contiene una batteria.

es www.sauter-controls.com ⇒ Products ⇒ Materialdeclaration
El dispositivo contiene una batería.
sv www.sauter-controls.com ⇒ Products ⇒ Materialdeclaration
Enheten har batteri.
nl www.sauter-controls.com ⇒ Products ⇒ Materialdeclaration
Apparaat bevat batterij.

de Dokument aufbewahren
fr Ce document est à conserver
en Retain this document
it Conservare il documento
es Guardar el documento
sv Spara dokumentationen
nl Document bewaren

© Fr. Sauter AG
Im Surinam 55
CH-4058 Basel
Tel. +41 61 - 695 55 55
Fax +41 61 - 695 55 10
www.sauter-controls.com
info@sauter-controls.com